



Where Automation Connects.



**inRAX<sup>®</sup>**  
**PC56**  
ControlLogix Platform  
In-Rack Industrial PC

October 22, 2010

**USER MANUAL**

## **Your Feedback Please**

We always want you to feel that you made the right decision to use our products. If you have suggestions, comments, compliments or complaints about our products, documentation, or support, please write or call us.

## **How to Contact Us**

### **ProSoft Technology**

5201 Truxtun Ave., 3rd Floor  
Bakersfield, CA 93309  
+1 (661) 716-5100  
+1 (661) 716-5101 (Fax)  
[www.prosoft-technology.com](http://www.prosoft-technology.com)  
[support@prosoft-technology.com](mailto:support@prosoft-technology.com)

**Copyright © 2010 ProSoft Technology, Inc., all rights reserved.**

PC56 User Manual

October 22, 2010

ProSoft Technology<sup>®</sup>, ProLinx<sup>®</sup>, inRAx<sup>®</sup>, ProTalk<sup>®</sup>, and RadioLinx<sup>®</sup> are Registered Trademarks of ProSoft Technology, Inc. All other brand or product names are or may be trademarks of, and are used to identify products and services of, their respective owners.

## **ProSoft Technology<sup>®</sup> Product Documentation**

In an effort to conserve paper, ProSoft Technology no longer includes printed manuals with our product shipments. User Manuals, Datasheets, Sample Ladder Files, and Configuration Files are provided on the enclosed CD-ROM, and are available at no charge from our web site: [www.prosoft-technology.com](http://www.prosoft-technology.com)

Printed documentation is available for purchase. Contact ProSoft Technology for pricing and availability.

North America: +1.661.716.5100

Asia Pacific: +603.7724.2080

Europe, Middle East, Africa: +33 (0) 5.3436.87.20

Latin America: +1.281.298.9109

## PC56 Products

WARNING - EXPLOSION HAZARD - DO NOT DISCONNECT EQUIPMENT UNLESS POWER HAS BEEN SWITCHED OFF OR THE AREA IS KNOWN TO BE NON-HAZARDOUS.

AVERTISSEMENT - RISQUE D'EXPLOSION - AVANT DE DÉCONNECTER L'EQUIPMENT, COUPER LE COURANT OU S'ASSURER QUE L'EMPLACEMENT EST DÉSIGNÉ NON DANGEREUX.

## Warnings

### ATEX Warnings and Conditions of Safe Usage

Power, Input, and Output (I/O) wiring must be in accordance with the authority having jurisdiction

- A** Warning - Explosion Hazard - When in hazardous locations, turn off power before replacing or wiring modules.
- B** Warning - Explosion Hazard - Do not disconnect equipment unless power has been switched off or the area is known to be non-hazardous.
- C** These products are intended to be mounted in an IP54 enclosure. The devices shall provide external means to prevent the rated voltage being exceeded by transient disturbances of more than 40%. This device must be used only with ATEX certified backplanes.
- D** DO NOT OPEN WHEN ENERGIZED.

## PC56™ Battery Warning

PC56 CMOS BIOS settings are protected by a rechargeable battery during power-down situations. The battery must be fully charged before you change BIOS settings. You must keep the unit powered up for a full 20 hours in order to obtain full charge capacity. If the battery is not fully charged, changes to BIOS settings may be lost when the PC56 is removed from its power source. In this situation, the PC56 reverts to its default BIOS settings when power is re-applied.

If the battery is discharged, or the battery enable jumper is removed, the BAT LED will be illuminated red. A fully charged battery should maintain the BIOS settings for 15 days without power.

## PC56 Markings

### Electrical Ratings

- Backplane Current Load on PC56: 1 A @ 5 Vdc
- Backplane Current Load on IDE: 1 A @ 5 Vdc
- Operating Temperature: 0°C to 60°C (32°F to 140°F)
- Storage Temperature: -40°C to 85°C (-40°F to 185°F)
- Shock: 30 g Operational; 50 g non-operational; Vibration: 5 g from 10 Hz to 150 Hz
- Relative Humidity 5% to 95% (without condensation)
- All phase conductor sizes must be at least 1.3 mm(squared) and all earth ground conductors must be at least 4mm(squared).

### Label Markings

II 3 G

Ex nA IIC X

0° C <= Ta <= 60° C

II - Equipment intended for above ground use (not for use in mines).

3 - Category 3 equipment, investigated for normal operation only.

G - Equipment protected against explosive gasses.

### Agency Approvals and Certifications

CE	EMC-EN61326-1:2006; EN6100-6-4:2007
CSA/cUL	C22.2 No. 213-1987
CSA CB Certified	IEC61010
ATEX	EN60079-0 Category 3, Zone 2 EN60079-15



243333



ME06

# Contents

Your Feedback Please.....	2
How to Contact Us.....	2
ProSoft Technology® Product Documentation.....	2
PC56 Products.....	3
Warnings.....	3
PC56™ Battery Warning.....	3
PC56 Markings.....	3
<b>1 Using This Manual</b>	<b>7</b>
1.1 Who Should Use This Manual.....	8
1.1.1 Additional Documentation.....	8
1.2 Reference Material.....	9
1.3 Product Specifications.....	10
1.3.1 Hardware Specifications.....	10
1.3.2 Environmental Specifications.....	11
1.3.3 Operating System.....	11
<b>2 Introducing PC56</b>	<b>13</b>
2.1 PC56 Overview.....	14
2.1.1 Key OEM Features.....	15
2.1.2 Benefits.....	15
2.1.3 PC56 Architecture.....	15
2.1.4 Compatibility Issues.....	15
2.1.5 PC56 Software Tools.....	15
<b>3 Installing PC56</b>	<b>17</b>
3.1 Setting Jumpers.....	18
3.1.1 Battery Enable/ CMOS Clear.....	18
3.1.2 Battery Enable.....	18
3.1.3 COM1 Mode Select.....	18
3.2 Inserting The Module.....	19
3.2.1 Turn ON power.....	19
<b>4 Reset, Auxiliary Timers and PCI Information</b>	<b>21</b>
4.1 Overview.....	22
4.1.1 Auxiliary Timer (WinCE Only).....	22
4.1.2 RESET: Functional Description.....	22
4.1.3 PCI Configuration Base Addresses.....	22
4.1.4 Four Character Alpha-Numeric Display.....	22
4.2 Using the USB Ports.....	23
<b>5 Troubleshooting</b>	<b>25</b>
5.1 FAQ.....	26

---

<b>6</b>	<b>Reference</b>	<b>29</b>
6.1	Memory Map .....	29
6.2	Cable Connections .....	30
6.2.1	RS-232 Configuration/Debug Port .....	30
6.2.2	RS-232 Application Port(s) .....	30
6.2.3	RS-422 .....	33
6.2.4	RS-485 Application Port(s) .....	33
6.2.5	DB9 to RJ45 Adaptor (Cable 14) .....	34
<b>7</b>	<b>Support, Service &amp; Warranty</b>	<b>35</b>
	Contacting Technical Support .....	35
7.1	Return Material Authorization (RMA) Policies and Conditions .....	37
7.1.1	Returning Any Product .....	37
7.1.2	Returning Units Under Warranty .....	38
7.1.3	Returning Units Out of Warranty .....	38
7.2	LIMITED WARRANTY .....	39
7.2.1	What Is Covered By This Warranty .....	39
7.2.2	What Is Not Covered By This Warranty .....	40
7.2.3	Disclaimer Regarding High Risk Activities .....	40
7.2.4	Intellectual Property Indemnity .....	41
7.2.5	Disclaimer of all Other Warranties .....	41
7.2.6	Limitation of Remedies ** .....	42
7.2.7	Time Limit for Bringing Suit .....	42
7.2.8	No Other Warranties .....	42
7.2.9	Allocation of Risks .....	42
7.2.10	Controlling Law and Severability .....	43
	<b>Index</b>	<b>45</b>

---

# 1 Using This Manual

## *In This Chapter*

❖ Who Should Use This Manual .....	8
❖ Reference Material .....	9
❖ Product Specifications .....	10

## 1.1 Who Should Use This Manual

Use this manual if you are responsible for designing, installing, programming, or troubleshooting control systems that use the ProSoft Technology ControlLogix PC56 module.

This manual is a guide for using the PC56. How you program PC56 or how your application functions depends on the software applications you install on PC56.

Because of the variety of uses for the products, those responsible for the application and use of this control equipment must satisfy themselves that all necessary steps have been taken to assure that each application and use meets all performance and safety requirements, including any applicable laws, regulations, codes and standards.

The illustrations, charts, sample programs and layout examples shown in the product literature are intended solely for purposes of example. Since there are many variables and requirements associated with any particular installation, ProSoft Technology does not assume responsibility or liability (to include intellectual property liability) for actual use.

### ***1.1.1 Additional Documentation***

In addition to this manual there is a PC56 "Getting Started Guide". There are also API manuals for the various operating systems. The "Windows API Users Manual" comes on a CD packaged with each PC56.

Each PC56 component ships with installation instructions. The user manuals and installation instructions are also available from the ProSoft Technology web site at [www.prosoft-technology.com](http://www.prosoft-technology.com).

## 1.2 Reference Material

---

<b>This Document</b>	<b>By:</b>	<b>Has this ISBN #</b>
PC Systems Architecture Series	MindShare, Inc.	ISBN: 0-201-40993-3
PCI Systems Architecture	Addison-Wesley Publishing Co.	
PC Systems Architecture Series	MindShare, Inc.	ISBN: 0-201-40996-8
ISA Systems Architecture	Addison-Wesley Publishing Co.	
PCI Hardware and Software Architecture and Design	Edward Solari and George Willse	ISBN: 0-929392-28-0

---

## 1.3 Product Specifications

### 1.3.1 Hardware Specifications

Specification	Description
CPU Processor	Embedded 500 MHz Processor
Memory	512 MB SDRAM System Memory, upgradeable to 1 GB 512 KB SRAM (Battery Backed)
Compact Flash	Compact Flash Type I or II socket
Ethernet Port	10/100T IEEE 802.3 Ethernet 1500 V rms at 50 Hz to 60 Hz for 60 s, applied as specified in section 5.3.2 of IEC 60950: 1991 Ethernet Broadcast Storm Resiliency = less than or equal to 5000 [ARP] frames-per-second and less than or equal to 5 minutes duration
Serial Port	Isolated Serial RS-232 / RS-422 / RS-485
USB Port	Two USB 2.0 / 1.1 High Speed Host
Connectors	VGA, 2 Ethernet, 2 USB
Battery	Rechargeable Lithium Vanadium Pentoxide
Jumpers	COM 1 Mode Selection Battery Enable/Clear CMOS Boot to SAFE STATE (default settings) Hardware Debugger Support
Switches	Recessed Reset Switch
LED/Display	4-digit alphanumeric status display 3 Status LEDs 1 User LED Red, Green, Off
Real-Time Clock	Precision RTC accurate to +/- 4 minutes per year
Timers	82C54 Timer Clock 14 MHz - Interrupt Interval 1.67619 US
Video	VGA 1920 x 1440 1280 x 1024 256 1024 x 768 56K 800 x 600 16 M 43 Hz Interlaced 56 through 85 Hz Refresh Rates

---

### **1.3.2 Environmental Specifications**

<b>Item</b>	<b>Specification</b>
Temperature	Non-Operating: 0 to 80 °C Operating: 0 to 60 °C Note: Storage media may limit operating
Form Factor	Single-slot ControlLogix module
Power Ratings	10 W Max power consumption (Backplane powered)

### **1.3.3 Operating System**

The PC56 modules are ordered and shipped with the selected operating system pre-installed on the module. Operating system versions are as follows:

- Windows XP
- Windows CE 5.0



## 2 Introducing PC56

### In This Chapter

❖ PC56 Overview .....	14
-----------------------	----

## 2.1 PC56 Overview

The PC56 enables you to easily integrate PLC (Programmable Logic Controller) and PC (Personal Computer) programs in a single platform. Think of PC56 as a PC or industrial computer that fits into the Rockwell Automation® 1756 ControlLogix® chassis.

The differences between PC56 and a normal PC are the added functions to better address the needs of the industrial controls user. One of these is the PC56's ability to directly communicate with the Rockwell Automation® 1756 ControlLogix® back plane.

Included with each PC56 are the APIs necessary to develop application code for a variety of Operating Systems. Currently supported Operating Systems include Windows CE and XP.

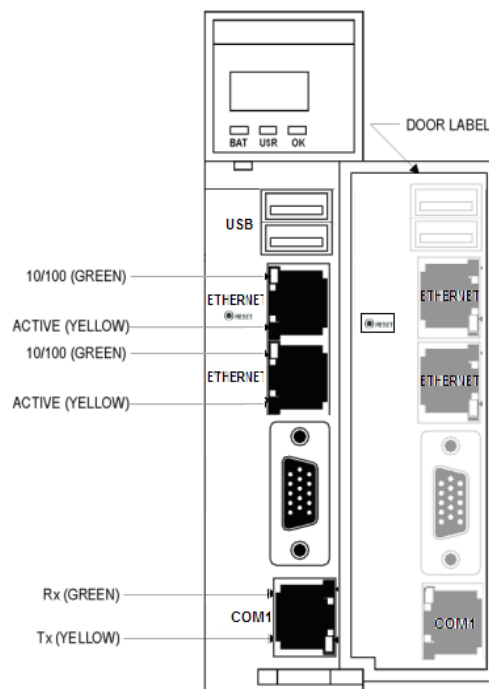

- Supports Windows CE or Windows XP
- Embedded 500MHz AMD processor
- Solid State, reliable operation
- 10/100 Base-T Ethernet
- Direct CLX processor read/write access
- Type II Compact Flash socket
- Stacking PCI Expansion Bus for high-speed connection to accessory modules
- Available 80 GB IDE Drive PCI Expansion Module

### **2.1.1 Key OEM Features**

The PC56 has several key features designed specifically to allow OEMs to develop the high performance applications needed in industrial automation applications:

- High Precision Real Time Clock
- Applications can be secured to module type and/or to module serial number
- Auxiliary timer (CE only)
- PowerFail Monitor (Allows data storage to BBRAM)

### **2.1.2 Benefits**

- Provides easy data collection connectivity
- Rigidly integrates traditional PLC and PC technology
- Integrates multiple vendor programs in a single chassis
- Enhances the control functions of the ControlLogix platform by adding the openness and processing power of the PC
- Meets net control and information automation requirements
- Perfect for tightly integrated OEM applications
- Meets new IT requirements

### **2.1.3 PC56 Architecture**

The continuing advances in processor technology have influenced the PC56 architecture. The speed at which new processors are introduced helped determine that a sub-module approach be used in the design of the PC56. The PC56 module consists of a two board stack, the ControlLogix<sup>®</sup> board and the CPU board.

The ControlLogix<sup>®</sup> board contains the components necessary to communicate with the 1756 backplane as well as all the physical interfaces on the front of the module. The PC56 interfaces with the ControlLogix<sup>®</sup> backplane through a shared memory window and uses a PCI interrupt. The memory window and interrupt are allocated by the system BIOS during the boot process.

The CPU board houses the processor, the PCI chipset and connector and the Ethernet chipset. These components are most likely to change with new advances in component technology.

### **2.1.4 Compatibility Issues**

PC56 is compatible with the Rockwell Automation 1756 ControlLogix chassis, the processors, ControlLogix software, power supplies, and all ControlLogix<sup>®</sup> I/O modules.

### **2.1.5 PC56 Software Tools**

In each PC56 package there is a CD with the Windows APIs and its manual. There is also example code included as well as source code for common tasks. Refer to the API manual for information.



## 3 Installing PC56

### *In This Chapter*

❖ Setting Jumpers .....	18
❖ Inserting The Module.....	19

Review the locations of the communications ports. Use the illustration on the front door of the module to locate the communication ports. Review the drawings included in this chapter to locate the jumpers that must be checked and, or changed as your application requires.

**Important:** Before you install PC56:

- Turn off power to the chassis
- Look at the three jumper settings:
  - COM1 port mode setting
  - Battery Enable/CMOS Clear
  - ControlLogix® Backplane shared memory allocation

### 3.1 Setting Jumpers

There are three jumpers to set, as your application requires.

#### 3.1.1 Battery Enable/ CMOS Clear

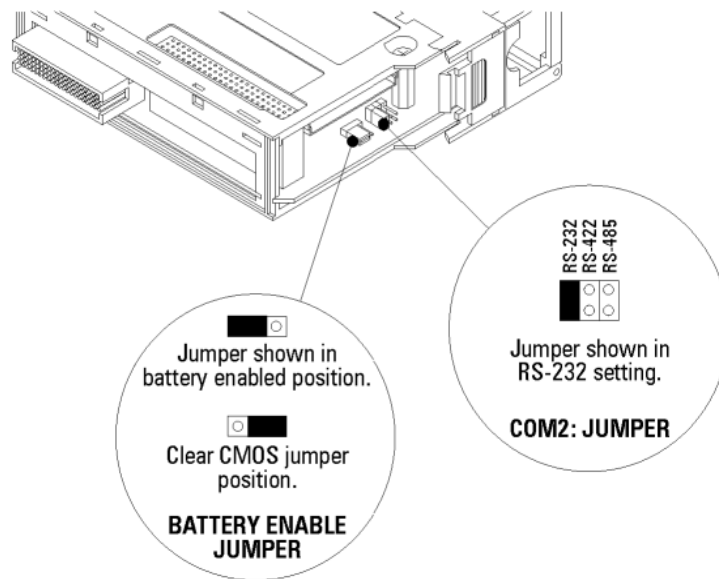

#### Clearing CMOS Memory

Insert the jumper in the CMOS Clear position momentarily if you want to clear CMOS memory and restore the default BIOS settings.

#### 3.1.2 Battery Enable

Place the jumper in the Battery Enable position to enable battery back-up of the system Real Time Clock, CMOS Memory, and 512 KByte battery-backed SRAM. If the PC56 is not going to be powered up for a long period of time, then it is advisable to remove the Battery Enable jumper to prevent complete discharge of the rechargeable battery.

#### 3.1.3 COM1 Mode Select

Used to set COM1 serial port to one of the three configurations listed.

## 3.2 Inserting The Module

After you have checked the placement of the jumpers, insert PC56 into the ControlLogix® chassis. Use the same technique recommended by Rockwell Automation to remove and install ControlLogix® modules.

Align the module with the top and bottom guides and slide into the rack until the module is firmly against the back plane connector. With a firm but steady push snap the module into place. Check that the holding clips on the top and bottom of the module are securely in the locking holes of the rack.

**Note:** Improper insertion of the module can cause unpredictable system behavior.

**Note:** *If you are installing PC56 with other modules connected to the PCI bus. The peripheral modules will not have holding clips. Make sure all of the modules are aligned with their respective slots before you snap them into place.*

### 3.2.1 Turn ON power

The PC56 will go through a POST routine that will check RAM and when complete will set the OK LED to GREEN. All other LEDs will be blank or OFF, unless your application sets them.



## 4 Reset, Auxiliary Timers and PCI Information

### *In This Chapter*

- ❖ Overview .....22
- ❖ Using the USB Ports .....23

## 4.1 Overview

In addition to the standard PC system hardware, PC56 contains the ControlLogix back plane interface circuitry with 512 MB SDRAM (upgradeable to 1 GB), an 82C54 timer, 512KBytes of battery-backed SRAM and a four character alpha-numeric display.

This chapter describes the functionality of the special hardware contained in the PC56 system.

### 4.1.1 Auxiliary Timer (WinCE Only)

The 82C54 timer shares a single PCI interrupt with the backplane support hardware, therefore your software must support sharing of this interrupt if you are going to use the timer in an application requiring the timer to initiate an interrupt. The 82C54 timer can also be configured to use the Non-Maskable Interrupt instead of a PCI interrupt. When the timer is configured to use NMI, then interrupt sharing between the timer and back plane hardware is not required..

### 4.1.2 RESET: Functional Description

A hardware reset occurs when the PC56 is powered up or when the reset switch is depressed. When a hardware reset occurs, the ControlLogix interface circuitry is reset, and its interrupt is disabled. The 82C54 timer interrupt is also disabled.

### 4.1.3 PCI Configuration Base Addresses

The PCI configuration space contains the addresses allocated to the shared RAM of the ControlLogix<sup>®</sup> interface circuitry and the SRAM as well as other PCI relevant addresses. The Vendor ID = 167Ch and Device ID = 0001h.

### 4.1.4 Four Character Alpha-Numeric Display

One of the unique features of PC56 is the front panel four character alphanumeric display. This display can scroll ASCII messages or display simple error codes. Refer to the API manual for information on how to write to this display.

## **4.2 Using the USB Ports**

PC56 has two high speed Universal Serial Bus 2.0 (USB) ports for connection to a variety of USB devices. USB device drivers are normally provided by the USB device manufacturer.



## 5 Troubleshooting

### In This Chapter

❖	FAQ.....	26
---	----------	----

If the system has been working properly, verify that the configuration has not been modified. This includes peripheral PCI module installation, jumper settings, BIOS settings, and cable connections. If needed, a module swap will verify a faulty module. Make sure that the system configuration is correct, and that the module you are replacing the suspect one with is a proven good one.

If the system has not been working properly, or you are installing the module for the first time, then review the jumper and BIOS settings.

## 5.1 FAQ

**Question:**

What do the LEDs mean?

**Answer:**

**BAT** - If this LED is ON if the battery is low, or if the Battery Enable jumper is not installed. As soon as power is applied to PC56, a low battery will begin to charge and the BAT LED will return to the OFF state within minutes. Twenty hours of continuous, powered-up operation will fully charge the battery.

**USR** - This LED is under program control and can be set to RED, GREEN, or OFF. Review the installed software program guide for information and state definitions.

**OK** - On power up, this LED is set to GREEN. During normal operation, if there is a problem communicating with the ControlLogix backplane it will be set to RED. This LED is under program and API control. It is sometimes referred to as the status LED. Refer to your application and the API manual for information.

**Question:**

How can I tell if a communications port is working properly?

**Answer:**

There are two LEDs associated with each communications port: the top one is green and the bottom one is yellow:

**GREEN:** Receive LED. This LED will momentarily turn ON when the serial port is receiving data from another device.

**YELLOW:** Transmit LED. This LED will momentarily turn ON when the serial port is transmitting data to another device.

**Question:**

Is PC56 slot dependent?

**Answer:**

No, but some consideration should be given to making room for any peripheral modules you are plugging onto the PCI bus.

**Question:**

Does the order I plug the PC56 peripherals on to the PCI bus matter?

**Answer:**

The PC56-IDE module, if used, should always be installed in the first slot to the left of the PC56 (Slot 0). Slot locations are numbered 0 through 2 starting at the first slot location to the left of the PC56. The PCI slot assignment jumper for each PCI peripheral module should be installed to match its corresponding physical slot location.

**Question:**

What is the maximum number of peripheral PCI modules I can plug onto PC56?

**Answer:**

Three unless otherwise specified.



## 6 Reference

### *In This Chapter*

- ❖ Memory Map .....29
- ❖ Cable Connections .....30

### 6.1 Memory Map

Address (hexadecimal)	Size (Kbytes)	Function
000000 to 09FFFF	640	System RAM
0A0000 to 0AFFFF	64	VGA Video Graphics RAM
0B0000 to 0BFFFF	32	VGA Enhanced Mode Graphics RAM
0B8000 to 0BFFFF	32	VGA Text RAM
0C0000 to 0CBFFF	48	VGA BIOS
0CC000 to CFFFFFF	16	Free Memory
0D0000 to 0DFFFF	64	Free Memory when ControlLogix® configuration jumper is set to 32 bit position. 64 Kbyte allocated by PCI BIOS for dual port memory when ControlLogix® configuration jumper is set to 16 bit position.
0E0000 to 0EFFFF	64	System BIOS
0F0000 to 0FFFFFF	64	System BIOS
0100000 to 07FFFFFF	1 to 128 Mbyte	System Extended Memory
08000000 to 0C000000	2 GByte to 3 GByte	Used to map memory windows requested by PCI peripherals

## 6.2 Cable Connections

The application ports on the PC56 module support RS-232, RS-422, and RS-485 interfaces. Please inspect the module to ensure that the jumpers are set correctly to correspond with the type of interface you are using.

**Note:** When using RS-232 with radio modem applications, some radios or modems require hardware handshaking (control and monitoring of modem signal lines). Enable this in the configuration of the module by setting the UseCTS parameter to 1.

### 6.2.1 RS-232 Configuration/Debug Port

This port is physically an RJ45 connection. An RJ45 to DB-9 adapter cable is included with the module. This port permits a PC based terminal emulation program to view configuration and status data in the module and to control the module. The cable for communications on this port is shown in the following diagram:

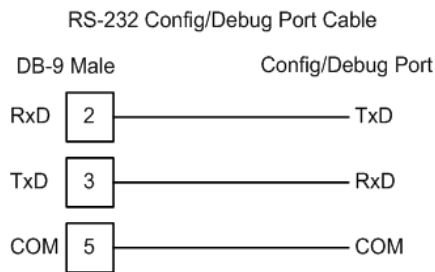

### 6.2.2 RS-232 Application Port(s)

When the RS-232 interface is selected, the use of hardware handshaking (control and monitoring of modem signal lines) is user definable. If no hardware handshaking will be used, here are the cable pinouts to connect to the port.

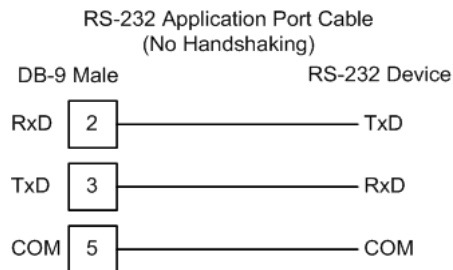

RS-232: Modem Connection (Hardware Handshaking Required)

This type of connection is required between the module and a modem or other communication device.

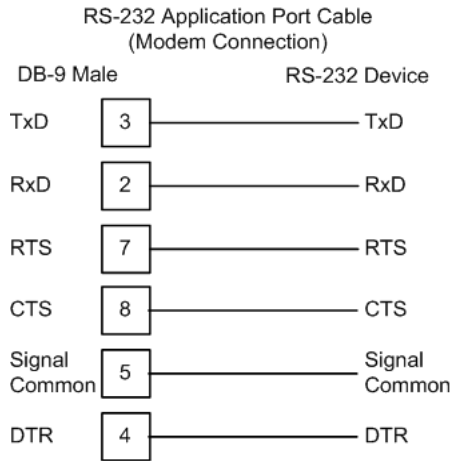

The "Use CTS Line" parameter for the port configuration should be set to 'Y' for most modem applications.

RS-232: Null Modem Connection (Hardware Handshaking)

This type of connection is used when the device connected to the module requires hardware handshaking (control and monitoring of modem signal lines).

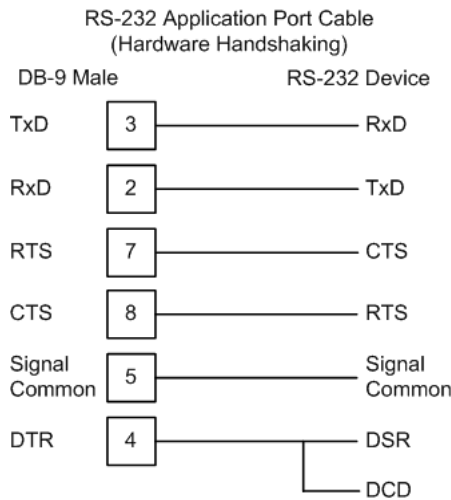

RS-232: Null Modem Connection (No Hardware Handshaking)

This type of connection can be used to connect the module to a computer or field device communication port.

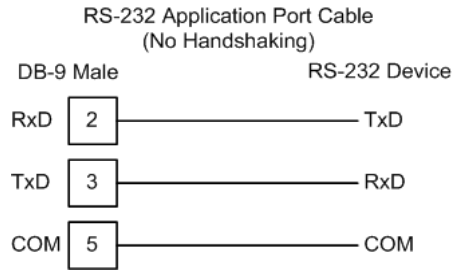

**Note:** For most null modem connections where hardware handshaking is not required, the *Use CTS Line* parameter should be set to **N** and no jumper will be required between Pins 7 (RTS) and 8 (CTS) on the connector. If the port is configured with the *Use CTS Line* set to **Y**, then a jumper is required between the RTS and the CTS lines on the port connection.

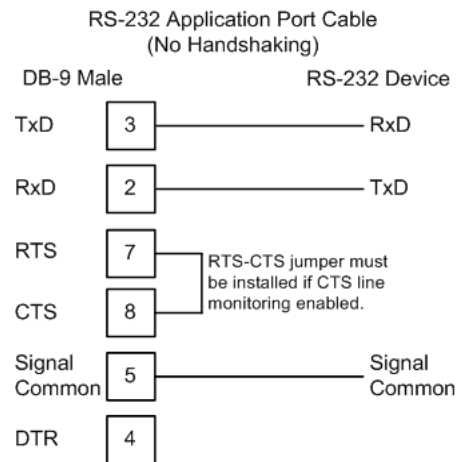

### 6.2.3 RS-422

The RS-422 interface requires a single four or five wire cable. The Common connection is optional, depending on the RS-422 network devices used. The cable required for this interface is shown below:

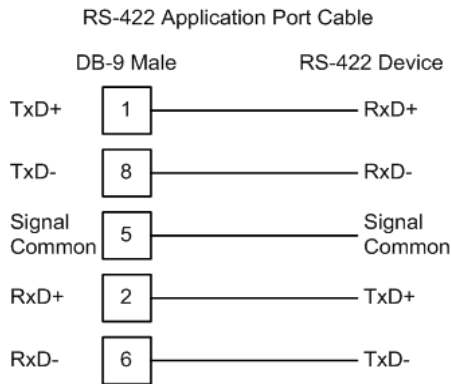

### 6.2.4 RS-485 Application Port(s)

The RS-485 interface requires a single two or three wire cable. The Common connection is optional, depending on the RS-485 network devices used. The cable required for this interface is shown below:

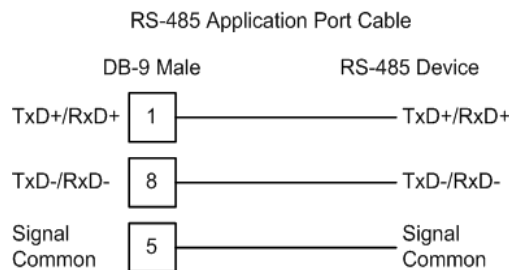

**Note:** Terminating resistors are generally not required on the RS-485 network, unless you are experiencing communication problems that can be attributed to signal echoes or reflections. In these cases, installing a 120-ohm terminating resistor between pins 1 and 8 on the module connector end of the RS-485 line may improve communication quality.

#### RS-485 and RS-422 Tip

If communication in the RS-422 or RS-485 mode does not work at first, despite all attempts, try switching termination polarities. Some manufacturers interpret + and -, or A and B, polarities differently.

### 6.2.5 DB9 to RJ45 Adaptor (Cable 14)

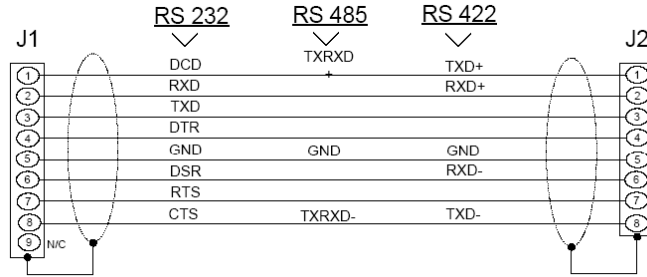
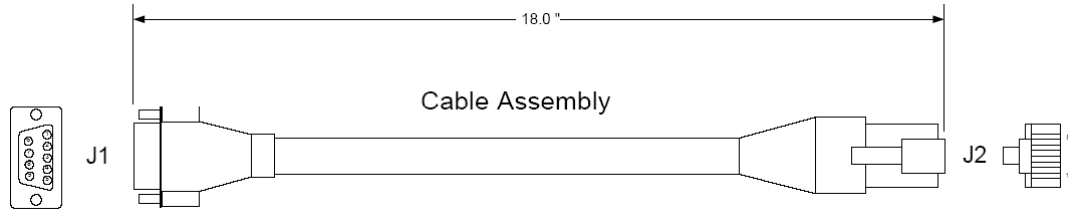

Wiring Diagram

## 7 Support, Service & Warranty

### In This Chapter

- ❖ Contacting Technical Support ..... 35
- ❖ Return Material Authorization (RMA) Policies and Conditions..... 37
- ❖ LIMITED WARRANTY..... 39

### **Contacting Technical Support**

ProSoft Technology, Inc. (ProSoft) is committed to providing the most efficient and effective support possible. Before calling, please gather the following information to assist in expediting this process:

- 1 Product Version Number
- 2 System architecture
- 3 Network details

If the issue is hardware related, we will also need information regarding:

- 1 Module configuration and associated ladder files, if any
- 2 Module operation and any unusual behavior
- 3 Configuration/Debug status information
- 4 LED patterns
- 5 Details about the serial, Ethernet or fieldbus devices interfaced to the module, if any.

**Note:** For technical support calls within the United States, an after-hours answering system allows 24-hour/7-days-a-week pager access to one of our qualified Technical and/or Application Support Engineers. Detailed contact information for all our worldwide locations is available on the following page.

---

<b>Internet</b>	Web Site: <a href="http://www.prosoft-technology.com/support">www.prosoft-technology.com/support</a> E-mail address: <a href="mailto:support@prosoft-technology.com">support@prosoft-technology.com</a>
<b>Asia Pacific</b> (location in Malaysia)	Tel: +603.7724.2080, E-mail: <a href="mailto:asiapc@prosoft-technology.com">asiapc@prosoft-technology.com</a> Languages spoken include: Chinese, English
<b>Asia Pacific</b> (location in China)	Tel: +86.21.5187.7337 x888, E-mail: <a href="mailto:asiapc@prosoft-technology.com">asiapc@prosoft-technology.com</a> Languages spoken include: Chinese, English
<b>Europe</b> (location in Toulouse, France)	Tel: +33 (0) 5.34.36.87.20, E-mail: <a href="mailto:support.EMEA@prosoft-technology.com">support.EMEA@prosoft-technology.com</a> Languages spoken include: French, English
<b>Europe</b> (location in Dubai, UAE)	Tel: +971-4-214-6911, E-mail: <a href="mailto:mea@prosoft-technology.com">mea@prosoft-technology.com</a> Languages spoken include: English, Hindi
<b>North America</b> (location in California)	Tel: +1.661.716.5100, E-mail: <a href="mailto:support@prosoft-technology.com">support@prosoft-technology.com</a> Languages spoken include: English, Spanish
<b>Latin America</b> (Oficina Regional)	Tel: +1-281-2989109, E-Mail: <a href="mailto:latinam@prosoft-technology.com">latinam@prosoft-technology.com</a> Languages spoken include: Spanish, English
<b>Latin America</b> (location in Puebla, Mexico)	Tel: +52-222-3-99-6565, E-mail: <a href="mailto:soporte@prosoft-technology.com">soporte@prosoft-technology.com</a> Languages spoken include: Spanish
<b>Brasil</b> (location in Sao Paulo)	Tel: +55-11-5083-3776, E-mail: <a href="mailto:brasil@prosoft-technology.com">brasil@prosoft-technology.com</a> Languages spoken include: Portuguese, English

---

## 7.1 Return Material Authorization (RMA) Policies and Conditions

The following Return Material Authorization (RMA) Policies and Conditions (collectively, "RMA Policies") apply to any returned product. These RMA Policies are subject to change by ProSoft Technology, Inc., without notice. For warranty information, see Limited Warranty (page 39). In the event of any inconsistency between the RMA Policies and the Warranty, the Warranty shall govern.

### 7.1.1 Returning Any Product

- a) In order to return a Product for repair, exchange, or otherwise, the Customer must obtain a Return Material Authorization (RMA) number from ProSoft Technology and comply with ProSoft Technology shipping instructions.
- b) In the event that the Customer experiences a problem with the Product for any reason, Customer should contact ProSoft Technical Support at one of the telephone numbers listed above (page 35). A Technical Support Engineer will request that you perform several tests in an attempt to isolate the problem. If after completing these tests, the Product is found to be the source of the problem, we will issue an RMA.
- c) All returned Products must be shipped freight prepaid, in the original shipping container or equivalent, to the location specified by ProSoft Technology, and be accompanied by proof of purchase and receipt date. The RMA number is to be prominently marked on the outside of the shipping box. Customer agrees to insure the Product or assume the risk of loss or damage in transit. Products shipped to ProSoft Technology using a shipment method other than that specified by ProSoft Technology, or shipped without an RMA number will be returned to the Customer, freight collect. Contact ProSoft Technical Support for further information.
- d) A 10% restocking fee applies to all warranty credit returns, whereby a Customer has an application change, ordered too many, does not need, etc. Returns for credit require that all accessory parts included in the original box (i.e.; antennas, cables) be returned. Failure to return these items will result in a deduction from the total credit due for each missing item.

### **7.1.2 Returning Units Under Warranty**

A Technical Support Engineer must approve the return of Product under ProSoft Technology's Warranty:

- a) A replacement module will be shipped and invoiced. A purchase order will be required.
- b) Credit for a product under warranty will be issued upon receipt of authorized product by ProSoft Technology at designated location referenced on the Return Material Authorization
  - i. If a defect is found and is determined to be customer generated, or if the defect is otherwise not covered by ProSoft Technology's warranty, there will be no credit given. Customer will be contacted and can request module be returned at their expense;
  - ii. If defect is customer generated and is repairable, customer can authorize ProSoft Technology to repair the unit by providing a purchase order for 30% of the current list price plus freight charges, duties and taxes as applicable.

### **7.1.3 Returning Units Out of Warranty**

- a) Customer sends unit in for evaluation to location specified by ProSoft Technology, freight prepaid.
- b) If no defect is found, Customer will be charged the equivalent of \$100 USD, plus freight charges, duties and taxes as applicable. A new purchase order will be required.
- c) If unit is repaired, charge to Customer will be 30% of current list price (USD) plus freight charges, duties and taxes as applicable. A new purchase order will be required or authorization to use the purchase order submitted for evaluation fee.

**The following is a list of non-repairable units:**

- 3150 - All
- 3750
- 3600 - All
- 3700
- 3170 - All
- 3250
- 1560 - Can be repaired, only if defect is the power supply
- 1550 - Can be repaired, only if defect is the power supply
- 3350
- 3300
- 1500 - All

## 7.2 LIMITED WARRANTY

This Limited Warranty ("Warranty") governs all sales of hardware, software, and other products (collectively, "Product") manufactured and/or offered for sale by ProSoft Technology, Incorporated (ProSoft), and all related services provided by ProSoft, including maintenance, repair, warranty exchange, and service programs (collectively, "Services"). By purchasing or using the Product or Services, the individual or entity purchasing or using the Product or Services ("Customer") agrees to all of the terms and provisions (collectively, the "Terms") of this Limited Warranty. All sales of software or other intellectual property are, in addition, subject to any license agreement accompanying such software or other intellectual property.

### 7.2.1 What Is Covered By This Warranty

- a) *Warranty On New Products:* ProSoft warrants, to the original purchaser, that the Product that is the subject of the sale will (1) conform to and perform in accordance with published specifications prepared, approved and issued by ProSoft, and (2) will be free from defects in material or workmanship; provided these warranties only cover Product that is sold as new. This Warranty expires three (3) years from the date of shipment for Product purchased **on or after** January 1st, 2008, or one (1) year from the date of shipment for Product purchased **before** January 1st, 2008 (the "Warranty Period"). If the Customer discovers within the Warranty Period a failure of the Product to conform to specifications, or a defect in material or workmanship of the Product, the Customer must promptly notify ProSoft by fax, email or telephone. In no event may that notification be received by ProSoft later than 39 months from date of original shipment. Within a reasonable time after notification, ProSoft will correct any failure of the Product to conform to specifications or any defect in material or workmanship of the Product, with either new or remanufactured replacement parts. ProSoft reserves the right, and at its sole discretion, may replace unrepairable units with new or remanufactured equipment. All replacement units will be covered under warranty for the 3 year period commencing from the date of original equipment purchase, not the date of shipment of the replacement unit. Such repair, including both parts and labor, will be performed at ProSoft's expense. All warranty service will be performed at service centers designated by ProSoft.
- b) *Warranty On Services:* Materials and labor performed by ProSoft to repair a verified malfunction or defect are warranted in the terms specified above for new Product, provided said warranty will be for the period remaining on the original new equipment warranty or, if the original warranty is no longer in effect, for a period of 90 days from the date of repair.

### **7.2.2 What Is Not Covered By This Warranty**

- a) ProSoft makes no representation or warranty, expressed or implied, that the operation of software purchased from ProSoft will be uninterrupted or error free or that the functions contained in the software will meet or satisfy the purchaser's intended use or requirements; the Customer assumes complete responsibility for decisions made or actions taken based on information obtained using ProSoft software.
- b) This Warranty does not cover the failure of the Product to perform specified functions, or any other non-conformance, defects, losses or damages caused by or attributable to any of the following: (i) shipping; (ii) improper installation or other failure of Customer to adhere to ProSoft's specifications or instructions; (iii) unauthorized repair or maintenance; (iv) attachments, equipment, options, parts, software, or user-created programming (including, but not limited to, programs developed with any IEC 61131-3, "C" or any variant of "C" programming languages) not furnished by ProSoft; (v) use of the Product for purposes other than those for which it was designed; (vi) any other abuse, misapplication, neglect or misuse by the Customer; (vii) accident, improper testing or causes external to the Product such as, but not limited to, exposure to extremes of temperature or humidity, power failure or power surges; or (viii) disasters such as fire, flood, earthquake, wind and lightning.
- c) The information in this Agreement is subject to change without notice. ProSoft shall not be liable for technical or editorial errors or omissions made herein; nor for incidental or consequential damages resulting from the furnishing, performance or use of this material. The user guide included with your original product purchase from ProSoft contains information protected by copyright. No part of the guide may be duplicated or reproduced in any form without prior written consent from ProSoft.

### **7.2.3 Disclaimer Regarding High Risk Activities**

Product manufactured or supplied by ProSoft is not fault tolerant and is not designed, manufactured or intended for use in hazardous environments requiring fail-safe performance including and without limitation: the operation of nuclear facilities, aircraft navigation or communication systems, air traffic control, direct life support machines or weapons systems in which the failure of the product could lead directly or indirectly to death, personal injury or severe physical or environmental damage (collectively, "high risk activities"). ProSoft specifically disclaims any express or implied warranty of fitness for high risk activities.

### **7.2.4 Intellectual Property Indemnity**

Buyer shall indemnify and hold harmless ProSoft and its employees from and against all liabilities, losses, claims, costs and expenses (including attorney's fees and expenses) related to any claim, investigation, litigation or proceeding (whether or not ProSoft is a party) which arises or is alleged to arise from Buyer's acts or omissions under these Terms or in any way with respect to the Products. Without limiting the foregoing, Buyer (at its own expense) shall indemnify and hold harmless ProSoft and defend or settle any action brought against such Companies to the extent based on a claim that any Product made to Buyer specifications infringed intellectual property rights of another party. ProSoft makes no warranty that the product is or will be delivered free of any person's claiming of patent, trademark, or similar infringement. The Buyer assumes all risks (including the risk of suit) that the product or any use of the product will infringe existing or subsequently issued patents, trademarks, or copyrights.

- a) Any documentation included with Product purchased from ProSoft is protected by copyright and may not be duplicated or reproduced in any form without prior written consent from ProSoft.
- b) ProSoft's technical specifications and documentation that are included with the Product are subject to editing and modification without notice.
- c) Transfer of title shall not operate to convey to Customer any right to make, or have made, any Product supplied by ProSoft.
- d) Customer is granted no right or license to use any software or other intellectual property in any manner or for any purpose not expressly permitted by any license agreement accompanying such software or other intellectual property.
- e) Customer agrees that it shall not, and shall not authorize others to, copy software provided by ProSoft (except as expressly permitted in any license agreement accompanying such software); transfer software to a third party separately from the Product; modify, alter, translate, decode, decompile, disassemble, reverse-engineer or otherwise attempt to derive the source code of the software or create derivative works based on the software; export the software or underlying technology in contravention of applicable US and international export laws and regulations; or use the software other than as authorized in connection with use of Product.
- f) **Additional Restrictions Relating To Software And Other Intellectual Property**

In addition to compliance with the Terms of this Warranty, Customers purchasing software or other intellectual property shall comply with any license agreement accompanying such software or other intellectual property. Failure to do so may void this Warranty with respect to such software and/or other intellectual property.

### **7.2.5 Disclaimer of all Other Warranties**

The Warranty set forth in What Is Covered By This Warranty (page 39) are in lieu of all other warranties, express or implied, including but not limited to the implied warranties of merchantability and fitness for a particular purpose.

### **7.2.6 Limitation of Remedies \*\***

In no event will ProSoft or its Dealer be liable for any special, incidental or consequential damages based on breach of warranty, breach of contract, negligence, strict tort or any other legal theory. Damages that ProSoft or its Dealer will not be responsible for include, but are not limited to: Loss of profits; loss of savings or revenue; loss of use of the product or any associated equipment; loss of data; cost of capital; cost of any substitute equipment, facilities, or services; downtime; the claims of third parties including, customers of the Purchaser; and, injury to property.

\*\* Some areas do not allow time limitations on an implied warranty, or allow the exclusion or limitation of incidental or consequential damages. In such areas, the above limitations may not apply. This Warranty gives you specific legal rights, and you may also have other rights which vary from place to place.

### **7.2.7 Time Limit for Bringing Suit**

Any action for breach of warranty must be commenced within 39 months following shipment of the Product.

### **7.2.8 No Other Warranties**

Unless modified in writing and signed by both parties, this Warranty is understood to be the complete and exclusive agreement between the parties, suspending all oral or written prior agreements and all other communications between the parties relating to the subject matter of this Warranty, including statements made by salesperson. No employee of ProSoft or any other party is authorized to make any warranty in addition to those made in this Warranty. The Customer is warned, therefore, to check this Warranty carefully to see that it correctly reflects those terms that are important to the Customer.

### **7.2.9 Allocation of Risks**

This Warranty allocates the risk of product failure between ProSoft and the Customer. This allocation is recognized by both parties and is reflected in the price of the goods. The Customer acknowledges that it has read this Warranty, understands it, and is bound by its Terms.

### ***7.2.10 Controlling Law and Severability***

This Warranty shall be governed by and construed in accordance with the laws of the United States and the domestic laws of the State of California, without reference to its conflicts of law provisions. If for any reason a court of competent jurisdiction finds any provisions of this Warranty, or a portion thereof, to be unenforceable, that provision shall be enforced to the maximum extent permissible and the remainder of this Warranty shall remain in full force and effect. Any cause of action with respect to the Product or Services must be instituted in a court of competent jurisdiction in the State of California.



# Index

## A

Additional Documentation • 8  
Allocation of Risks • 42  
Auxiliary Timer (WinCE Only) • 22

## B

Battery Enable • 18  
Battery Enable/ CMOS Clear • 18  
Benefits • 15

## C

Cable Connections • 30  
COM1 Mode Select • 18  
Compatibility Issues • 15  
Contacting Technical Support • 35, 37  
Controlling Law and Severability • 43

## D

DB9 to RJ45 Adaptor (Cable 14) • 34  
Disclaimer of all Other Warranties • 41  
Disclaimer Regarding High Risk Activities • 40

## E

Environmental Specifications • 11

## F

FAQ • 26  
Four Character Alpha-Numeric Display • 22

## H

Hardware Specifications • 10  
How to Contact Us • 2

## I

Inserting The Module • 19  
Installing PC56 • 17  
Intellectual Property Indemnity • 41  
Introducing PC56 • 13

## K

Key OEM Features • 15

## L

Limitation of Remedies \*\* • 42  
LIMITED WARRANTY • 37, 39

## M

Memory Map • 29

## N

No Other Warranties • 42

## O

Operating System • 11  
Overview • 22

## P

PC56 Architecture • 15  
PC56 Markings • 3  
PC56 Overview • 14  
PC56 Products • 3  
PC56 Software Tools • 15  
PC56™ Battery Warning • 3  
PCI Configuration Base Addresses • 22  
Pinouts • 30, 34  
Product Specifications • 10  
ProSoft Technology® Product Documentation • 2

## R

Reference • 29  
Reference Material • 9  
RESET  
    Functional Description • 22  
Reset, Auxiliary Timers and PCI Information • 21  
Return Material Authorization (RMA) Policies and  
    Conditions • 37  
Returning Any Product • 37  
Returning Units Out of Warranty • 38  
Returning Units Under Warranty • 38  
RS-232  
    Modem Connection (Hardware Handshaking  
        Required) • 31  
    Null Modem Connection (Hardware Handshaking)  
        • 31  
    Null Modem Connection (No Hardware  
        Handshaking) • 32  
RS-232 Application Port(s) • 30  
RS-232 Configuration/Debug Port • 30  
RS-422 • 33  
RS-485 and RS-422 Tip • 33  
RS-485 Application Port(s) • 33

## S

Setting Jumpers • 18  
Support, Service & Warranty • 35

## T

Time Limit for Bringing Suit • 42  
Troubleshooting • 25  
Turn ON power • 19

## U

Using the USB Ports • 23  
Using This Manual • 7

## W

Warnings • 3  
What Is Covered By This Warranty • 39, 41  
What Is Not Covered By This Warranty • 40

Who Should Use This Manual • 8

**Y**

Your Feedback Please • 2